

Reversible Motor

90 Watt

Frame Size: 90 mm

30 Minute rating, TEFC Aluminium Body.
 Quick Reversal of Direction of Rotation.
 Continuously Acting Internal Brake.
 Terminal Box or Open Lead Wires for Connection.



Specifications:

Model	Supply Voltage	Frequency Hz	Current A	Starting Torque N.m	Rated Torque N.m	Rated Speed RPM	Capacitor µF
90 RW 4□ 90	Single Phase 110V	50	1.80	0.45	0.69	1300	25.0
90 RW 4□ 90	Single Phase 110V	60	1.80	0.45	0.57	1550	40.0
90 RX 4□ 90	Single Phase 230V	50	0.85	0.45	0.69	1300	10.0
90 RY 4□ 90	Three Phase 230V	50	0.75	0.75	0.70	1300	—
90 RY 4□ 90	Three Phase 230V	60	0.65	0.69	0.57	1600	—
90 RY 4□ 90	Three Phase 415V	50	0.40	0.75	0.70	1300	—

□ Type Of Shaft, G for Gear Shaft, R for Round Shaft

Gearmotor Torque Table:

The maximum permissible torque is 20 N.m

50 Hz

Unit : N.m

RPM	500	416	300	250	200	166	120	100	83	60	50	41	30	25	20	16	15	12.5	10	8.3
Gear Ratio	3	3.6	5	6	7.5	9	12.5	15	18	25	30	36	50	60	75	90	100	120	150	180
Output Torque	1.7	2.0	2.8	3.3	4.2	5.0	6.3	7.5	9.1	11.2	13.4	16.1	20.0	20.0	20.0	20.0	20.0	20.0	20.0	20.0

60 Hz

Unit : N.m

RPM	600	500	360	300	240	200	144	120	100	72	60	50	30	30	24	20	18	15	12	10
Gear Ratio	3	3.6	5	6	7.5	9	12.5	15	18	25	30	36	50	60	75	90	100	120	150	180
Output Torque	1.4	1.7	2.4	2.8	3.6	4.3	5.3	6.4	7.7	9.7	11.6	13.9	19.3	20.0	20.0	20.0	20.0	20.0	20.0	20.0

The Gear boxes are sold separately.

A coloured background indicates gear shaft rotation in same direction as motor shaft.

A white background indicates gear shaft rotation in opposite direction to the motor shaft.

The speed of geared motor is calculated by dividing motor's synchronous speed by the gear ratio.

The actual speed is less than the displayed value, depending upon the load.

Characteristics, specifications and dimensions are subject to change without notice.

Dimensions:

Motor, Gearbox with Terminal Box

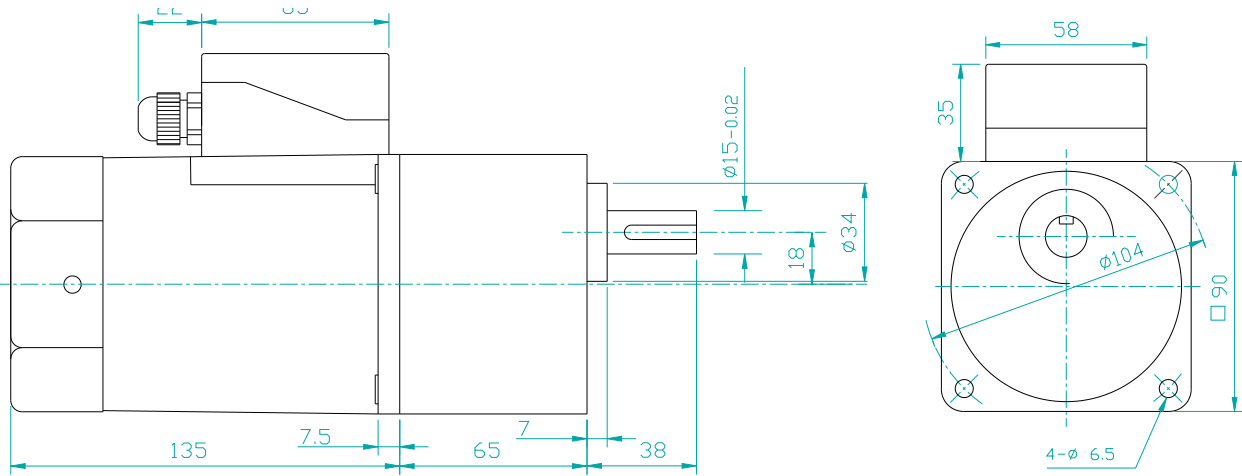

Motor Round Shaft with Terminal Box

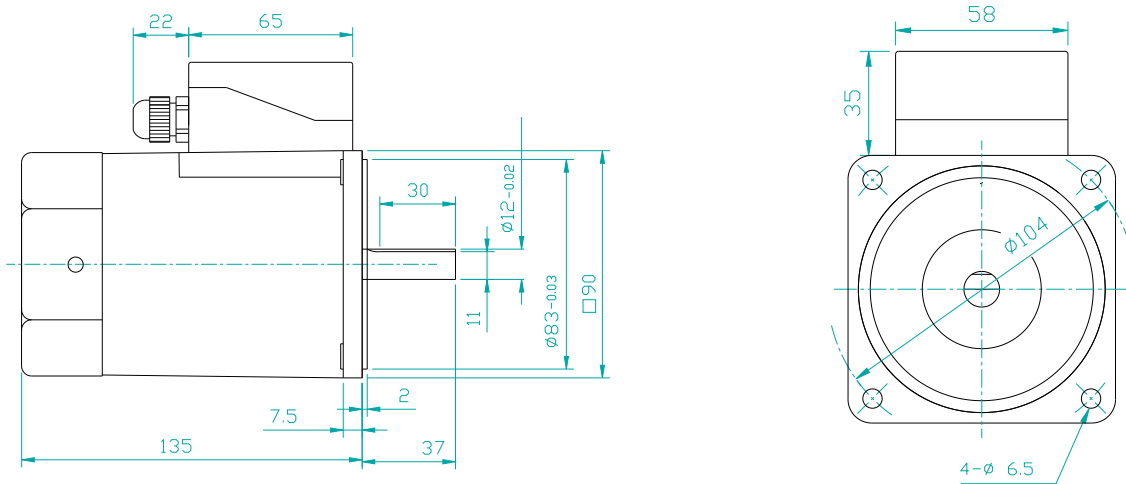

Motor, Gearbox with Lead Wires

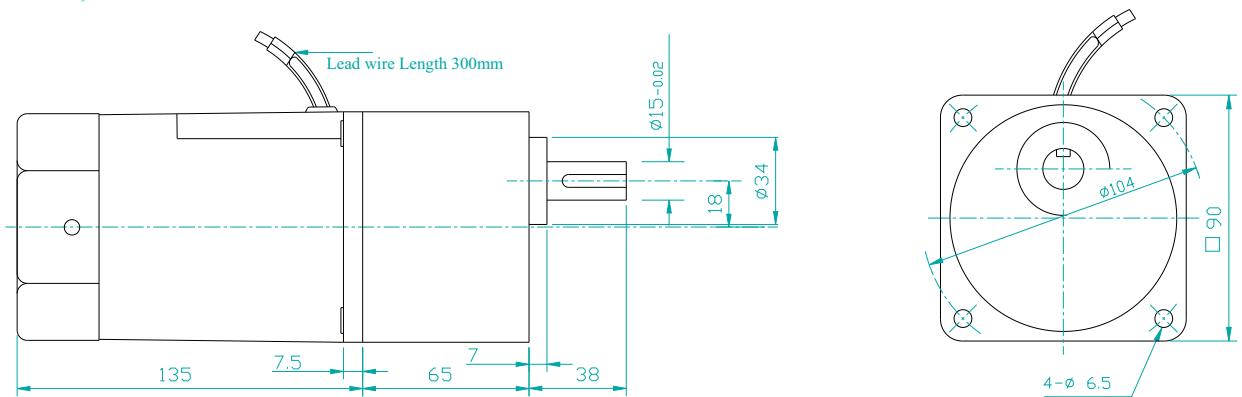

Key & Keyway

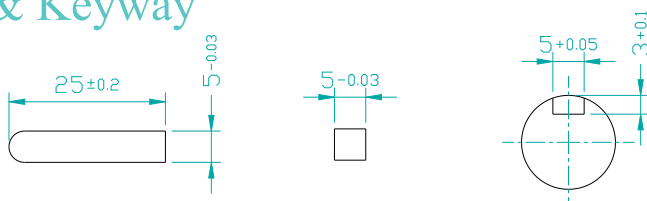

Weight: Motor 3 Kg

Gear Box 1.5 Kg

Reversible Motor

Wiring Diagram:

Wiring Diagram for Single Phase Motor

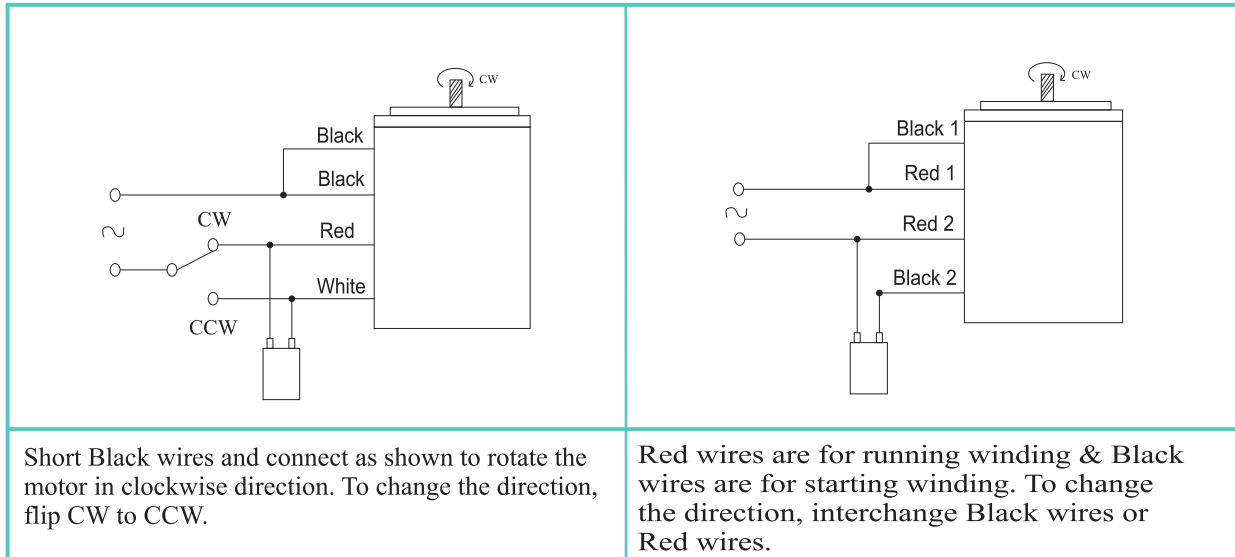

Wiring Diagram for Three Phase Motor

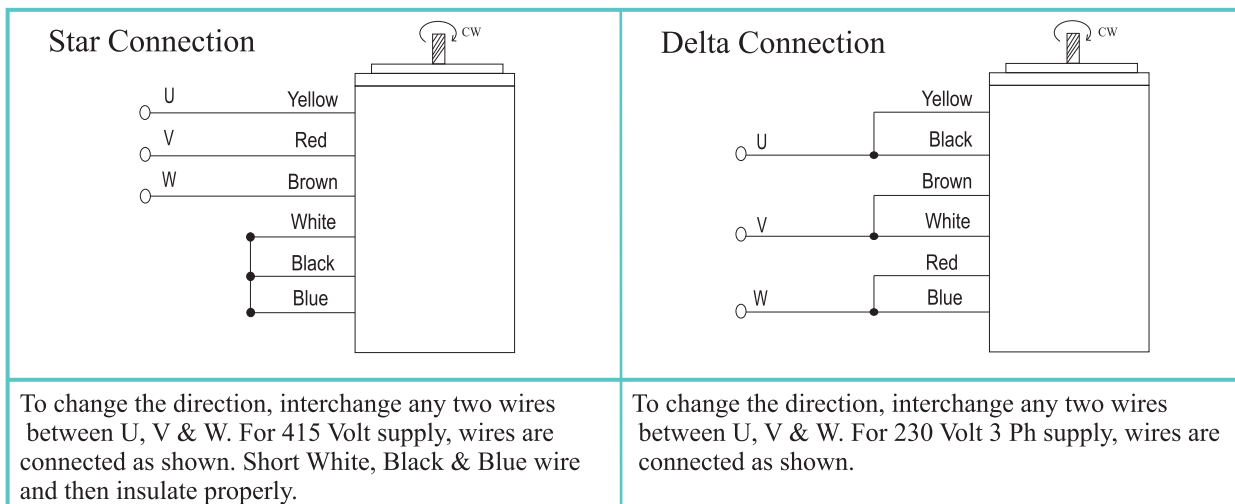

Change the direction of the motor only after it stops rotating. If the attempt is made during rotation, motor may ignore the reversing command or change the direction after some time.